

Engineering Specification

Job Name _____
 Job Location _____
 Engineer _____
 Approval _____

Contractor _____
 Approval _____
 Contractor's P.O. No. _____
 Representative _____

LEAD FREE*

Series 994 Reduced Pressure Zone Assemblies

Sizes: 2½" – 10"

Series 994 Reduced Pressure Zone Assemblies are designed to provide protection of the potable water supply in accordance with national codes. This series can be used where approved by the local authority having jurisdiction on health hazard cross-connections. Series 994 features a short lay length, lightweight stainless steel body, corrosion resistant stainless steel relief valve, and patented torsion spring check valves.

Features

- Stainless steel construction provides long term corrosion resistance and maximum strength
- Stainless steel body is half the weight of competitive designs reducing installation & shipping costs
- Short end-to-end dimensions makes retrofit easy
- Bottom mounted relief valve reduces clearance requirements when installed against an outside wall
- Torsion spring check valves provides maximum flow at low pressure drop
- Thermoplastic & stainless steel check valves for trouble-free operation
- No special tools required for servicing
- Compact construction allows for smaller enclosures
- Stainless steel relief valve features a balanced rolling diaphragm to eliminate sliding seals and lower maintenance costs

Specifications

A Reduced Pressure Zone Assembly shall be installed at each cross-connection to prevent backsiphonage and backpressure of hazardous materials into the potable water supply. The assembly shall consist of a pressure differential relief valve located in a zone between two positive seating check valves. The main valve body shall be manufactured from 300 Series stainless steel for corrosion resistance. The check valves shall be of thermoplastic construction with stainless steel hinge pins, cam arm, and cam bearing. The check valve shall utilize a single torsion spring design to minimize pressure drop through the assembly. The check valves shall be modular and shall seal to the main valve body by the use of an O-ring. There shall be no brass or bronze parts used within the check assembly or relief valve. The use of seat screws to retain the check valve seat is prohibited. All internal parts shall be accessible through a single cover on the valve assembly securely held in place by a two-bolt grooved coupling. The differential relief valve shall be of stainless steel construction and shall utilize a rolling diaphragm and no sliding seals. The relief valve shall be bottom mounted and supplied with a steel reinforced sensing hose. The assembly shall include two resilient seated shutoff valves & four ball type test cocks. The assembly shall be a Watts Series 994.

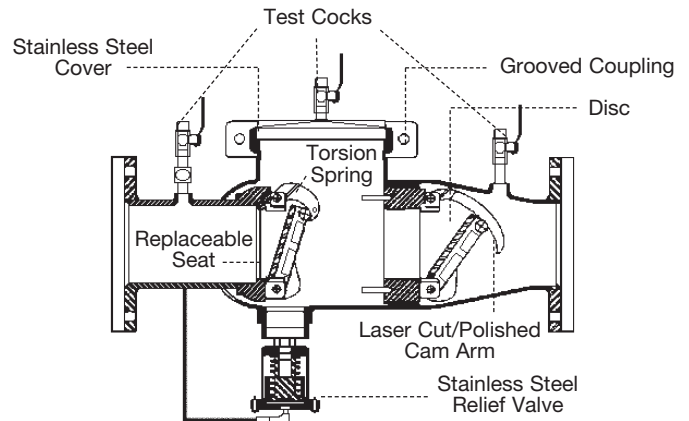
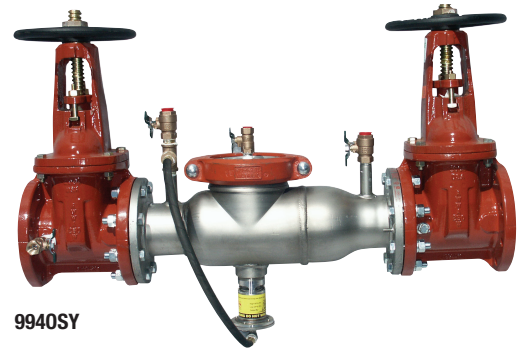

Models

Suffix:

- NRS – non-rising stem resilient seated gate valves
- OSY – UL/FM outside stem & yoke resilient seated gate valves
- **OSY FxG – flanged inlet gate connection and grooved outlet gate connection
- **OSY GxF – grooved inlet gate connection and flanged outlet gate connection
- **OSY GxG – grooved inlet gate connection and grooved outlet gate connection
- LF – without shutoff valves
- S – cast iron strainer

Available with grooved NRS gate valves - consult factory**
 Post indicator plate and operating nut available - consult factory**
 **Consult factory for dimensions

Note: The installation of a drain line is recommended. When installing a drain line, a 994AGK-P air gap is necessary. See ES-AG/EL/TC for additional information.

Now Available
WattsBox Insulated Enclosures.
 For more information, send for literature ES-WB.

IMPORTANT: INQUIRE WITH GOVERNING AUTHORITIES FOR LOCAL INSTALLATION REQUIREMENTS

*The wetted surface of this product contacted by consumable water contains less than one quarter of one percent (0.25%) of lead by weight.

Watts product specifications in U.S. customary units and metric are approximate and are provided for reference only. For precise measurements, please contact Watts Technical Service. Watts reserves the right to change or modify product design, construction, specifications, or materials without prior notice and without incurring any obligation to make such changes and modifications on Watts products previously or subsequently sold.



Materials

All internal metal parts: 300 Series stainless steel
 Main valve body: 300 Series stainless steel
 Check assembly: Noryl®
 Flange dimension in accordance with AWWA Class D

Pressure – Temperature

Temperature Range: 33°F – 110°F (0.5°C – 43°C) continuous
 Maximum Working Pressure: 175psi (12.1 bar)

Capacity *Typical maximum flow rate (7.5 feet/sec.) **UL rated flow

Standards

AWWA C511-92, CSA B64.5, UL Classified

Approvals



Approved by the Foundation for Cross Connection Control & Hydraulic Research at the University of Southern California Sizes 2½" – 6"

Series 994 performance as established by an independent testing laboratory (1996 UL)

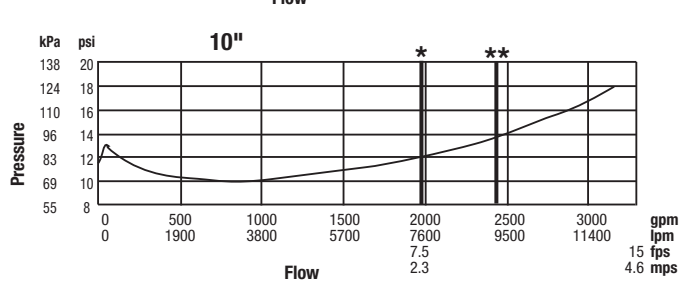
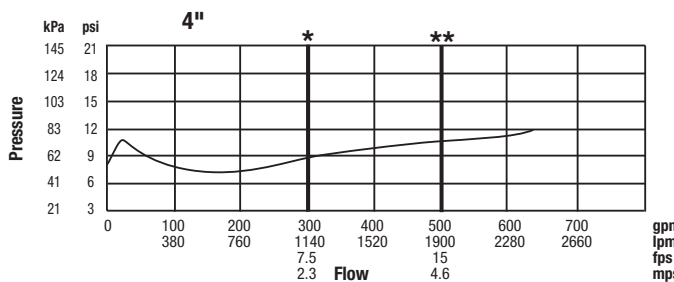
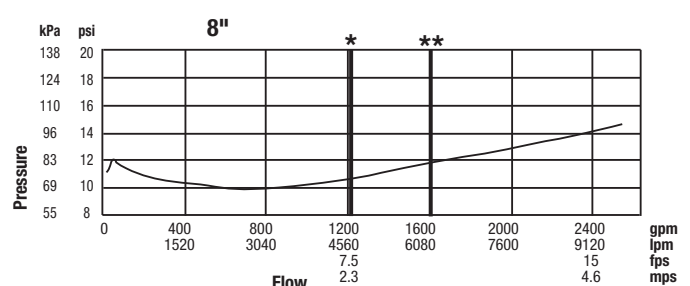
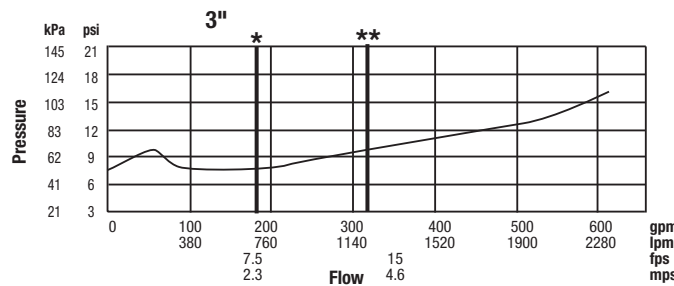
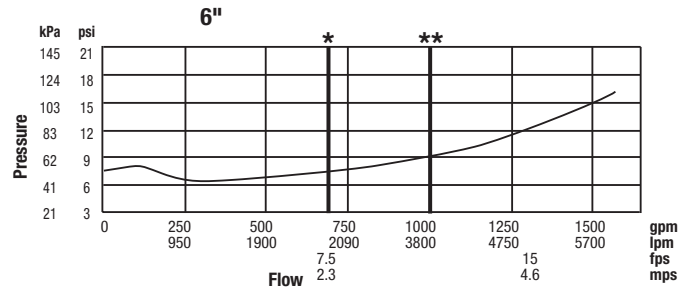
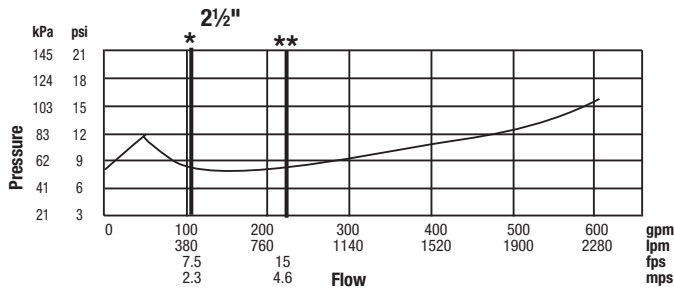

Dimensions – Weights

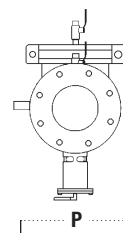
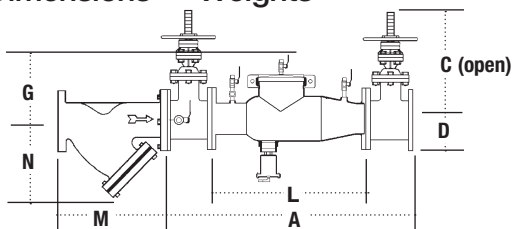

Air Gap Assembly

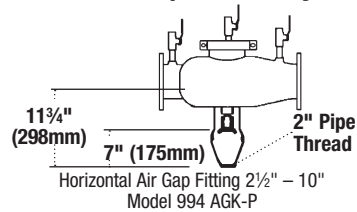

SIZE	DIMENSIONS										WEIGHT											
	A		C (OSY)		C (NRS)		D		G		L		M		N		P		w/Gates		w/o Gates	
in.	in.	mm	in.	mm	in.	mm	in.	mm	in.	mm	in.	mm	in.	mm	in.	mm	in.	mm	lbs.	kgs.	lbs.	kgs.
2½	37	940	16¾	416	9¾	238	10½	267	10	254	22	559	10	254	6½	165	7	178	148	67	60	27
3	38	965	18¾	479	10¼	260	10½	267	10	254	22	559	10½	257	7	178	7½	191	226	103	62	28
4	40	1016	22¾	578	12¾	310	10½	267	10	250	22	559	12½	308	8¼	210	9	229	235	107	65	30
6	48½	1232	30¾	765	16	406	11½	292	15	381	27½	699	18½	470	13½	343	11	279	380	172	110	50
8	52½	1334	37¾	959	19½	506	12½	318	15	381	29½	749	21½	549	15½	394	13½	343	571	259	179	81
10	55¾	1416	45¾	1162	23½	605	12½	318	15	381	29½	749	26	660	18½	470	16	406	773	351	189	86

Noryl® is a registered trademark of SABIC Innovative Plastics™.

